

RECOMMENDED PCB LAYOUT
GENERAL TOLERANCE ± 0.05

CKT	DIM A	DIM B	DIM C
070	17.00	19.30	20.70
040	9.50	11.80	13.20
032	7.50	9.80	11.20

NOTES:

1. MATERIAL:

- 1.1 HOUSING: SOMIKASUPER LCP E6808L-BLACK, HIGH TEMP.,UL94V-0
- 1.2 CONTACT: PHOSPHOR BRONZE(C5191-H)

2. FINISH:

CONTACT:

CONTACT:SEE ORDER INFORMATION.
UNDERPLATING: 50~100u" NICKEL OVERALL

3. SPEC. PLS. REFER TO PS-51093-XXXXX-XXX

4. PACKAGE PLS. REFER TO 51093-XXXCR-XX

5. PART NUMBER

51093-XXX X X- 001

NO OF CKT:

PACKING:

0: TAPE & REEL

PLATING:

1:G/F ON CONTACT AND SOLDER
C:15u" GOLD ON CONTACT AND
G/F PLATING ON SOLDER.

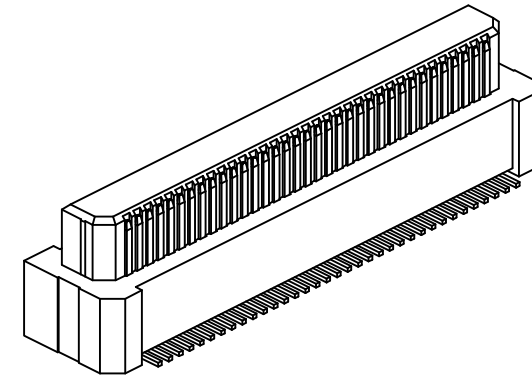

QUALITY SYMBOLS MAJOR Ⓜ CRITICAL Ⓢ	DRAWN BY TSO I CHIAO	DATE 21/03/25	
	CHECKED BY Chen, Chun Yuan	DATE 21/03/25	
GENERAL TOLERANCES (UNLESS SPECIFIED) .X ±0.5 .X ±0.25 .XX ±0.15 .XXX ±0.1 ANGLES ±2°	APPROVED BY Huang Kuo Hua	DATE 21/03/25	TITLE 0.50mm PITCH BOARD TO BOARD CONN (PLUG)
	UNITS mm		SIZE A4
SCALE 2 : 1	SHEET NO. 1 OF 1	REV B	PART NO. SEE NOTES